



RAY CAMP COMPANY

QUALITY HIGH CAPACITY BAG FILTER HOUSINGS



Model 4 Bag Filter Housings Sizes #3 & #4 Strainers or Bag Filters: Your Choice!

Model 4 strainer/filter housings are made in 2 sizes. In all cases, covers are easily removed without special tools.

Features

- Low pressure drops
- Permanently-piped housings
- Covers are O-ring sealed
- Carbon steel, stainless steel (304 or 316) and aluminum construction for housings
- Easy to clean!
- Adjustable-height legs, standard
- Pipe sizes 3/4 thru 2-inch, NPT or flanged (standard 150 class flange)
- Two basket depths: 6 or 12 inches (nominal)

Options

- Sanitary connections
- Different outlet connections
- Extra-length legs
- Liquid displacers for easier servicing

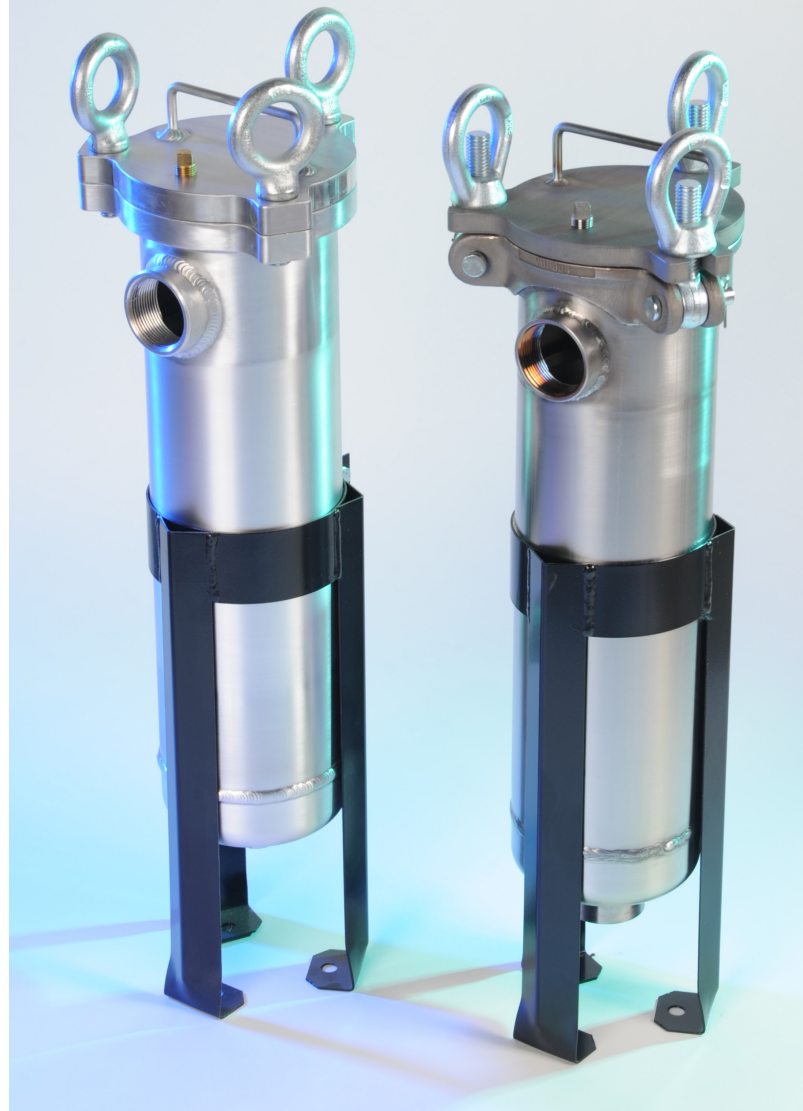

Model 4 shown in Aluminum and Stainless Steel



Model 4 shown in Carbon Steel

Choosing A Basket Strainer or Bag Filter

Choose between straining (removing particles down to 74 micron size) or filtering a fluid (removing particles down to 1 micron size). This will direct you to choose the correct basket when ordering.

Operation

Unfiltered liquid enters the housing above the bag or basket and passes down through them. Solids are contained inside the bag or basket, where they're easily and completely removed when the unit is serviced.

Fluid bypass around the basket is prevented because the outside diameter of the filter bag seals radially against the housing inside diameter. A single cover gasket is used to seal the opening, and covers can be installed and removed without tools.

Model 4 Pressure Drop Data

Basket strainer and bag filters are usually selected so that the pressure drop does not exceed 2 psi, when they are clean. Higher pressure drops may be tolerated, when contaminant loading is low. Bag change out should occur at 15 psid.

The pressure drop data is accurate for all housings with strainer or bag filter baskets. When bag filters are added, total pressure drop becomes the sum of the pressure drop as determined by the steps below.

Follow these easy steps:

- 1) Using the desired pipe size and approximate flow rate, determine the basic pressure drop from the appropriate graph.
- 2) Multiply the pressure drop obtained in step 1 by the viscosity correction factor found in the accompanying table. This is the adjusted (clean) pressure drop for all baskets, without filter bags.
- 3) Add the pressure drop for the bag filter.

	Viscosity, cps								
	1 (H ₂ O)	50	100	200	400	600	800	1000	2000
Bag style and All unlined baskets	.65	.85	1.00	1.10	1.20	1.40	1.50	1.60	1.80
40-mesh lined	.73	.95	1.20	1.40	1.50	1.80	1.90	2.00	2.30
60-mesh lined	.77	1.00	1.30	1.60	1.70	2.10	2.20	2.30	2.80
80-mesh lined	.93	1.20	1.50	1.90	2.10	2.40	2.60	2.80	3.50
100-mesh lined	1.00	1.30	1.60	2.20	2.40	2.70	3.00	3.30	4.40
200-mesh lined	1.30	1.70	2.10	3.00	3.40	3.80	4.40	5.00	6.80

Basket Data

Depth Nominal (inches)	Diameter (inches)	Surface Area (sq. ft.)	Volume (cu. in.)	Bag Size No.
6	3.9	0.5	65	3
12	3.9	1.0	130	4



Model 4 shown in Aluminum

Model 4 — For flow rates to 50 gpm*

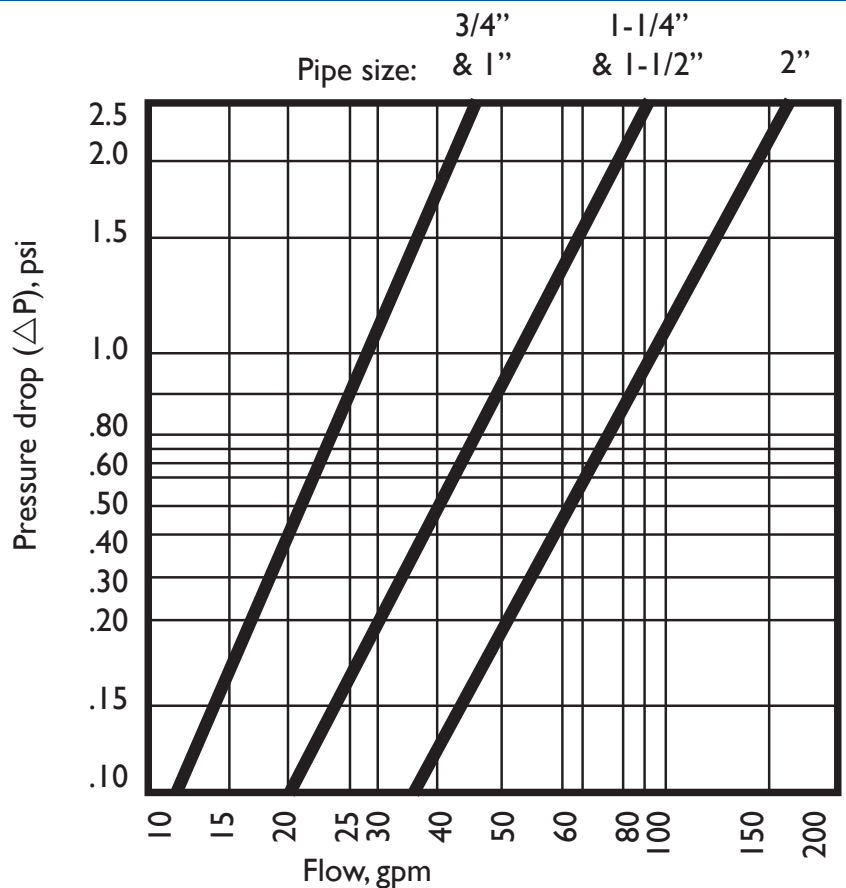

* Based on housing only. Fluid viscosity, bag filter used, and expected dirt loading should be considered when sizing a filter.

How To Order Model 4: Size #3 & #4 Filter Bag Housings

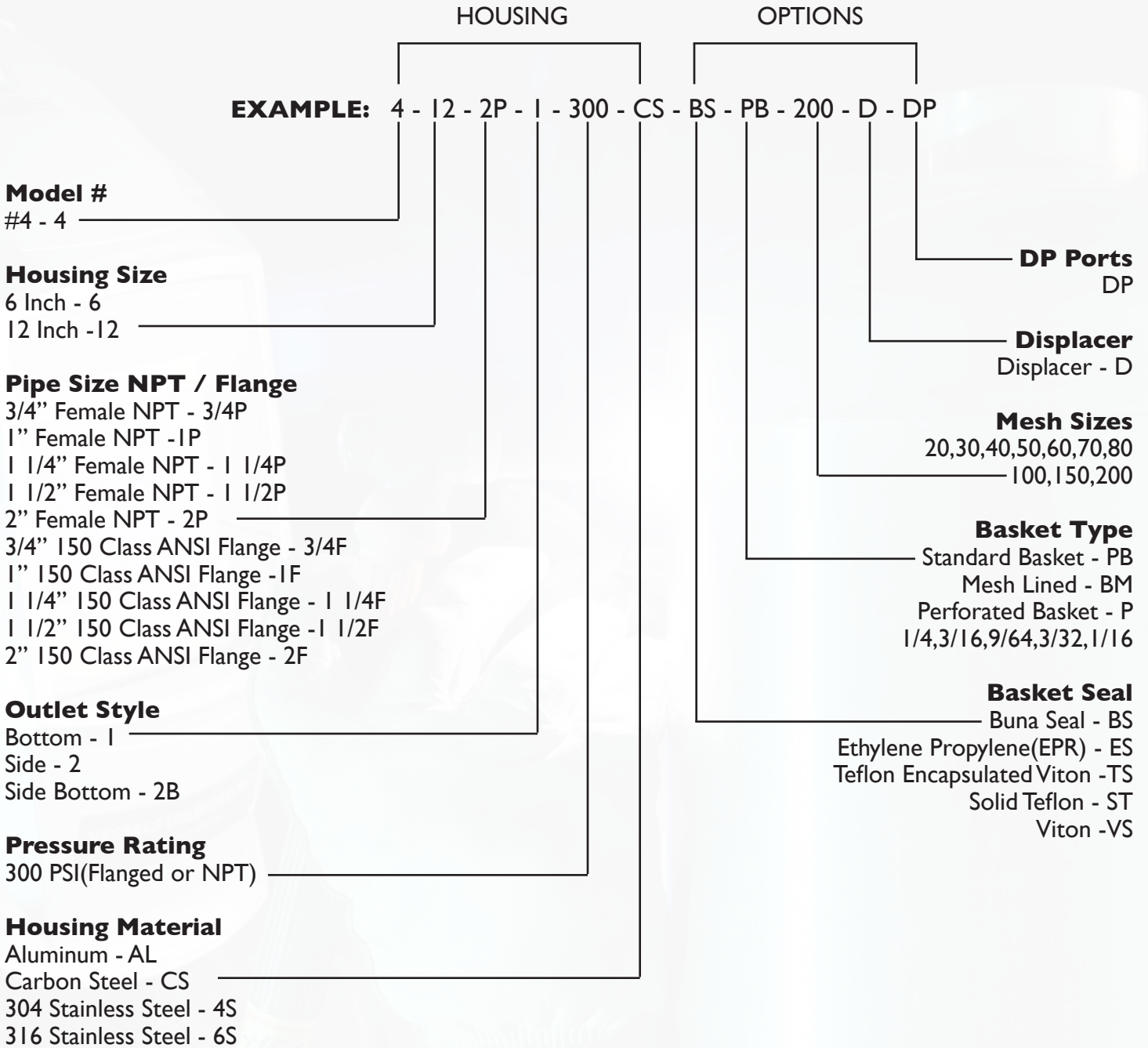

* Aluminum Housings only available with Eye Bolt Covers

* Carbon Steel & Stainless Housing only available with Hinged Eye Bolt Covers

* All Filter Bag Housings come with Carbon Steel Legs & Standard 304 SS Basket

* 304 Stainless & 316 Stainless Legs are available & 316 SS Baskets are available

Model 6 Bag Filter Housings Sizes #7, #8, & #9 Strainers or Bag Filters: Your Choice!

Model 6 strainer/filter housings are made in 3 sizes and can serve as basket strainers (for particle retention down to 74 micron size) or as bag filters (for particle retention down to 1 micron size). In all cases, covers are easily removed without special tools.

Features

- Low pressure drops
- Permanently-piped housings
- Covers are O-ring sealed
- Carbon steel or stainless steel (304 or 316) and aluminum construction for housings
- Easy to clean!
- Adjustable-height legs, standard
- O-Ring seals: Buna N, EPR, Viton®, teflon®
- Three basket depths: 12, 18, or 30 inches (nominal)

Options

- Sanitary connections
- Different outlet connections
- Extra-length legs
- Liquid displacers for easier servicing



Model shown in Stainless Steel



Choosing A Basket Strainer or Bag Filter

Choose between straining (removing particles down to 74 micron size) or filtering a fluid (removing particles down to 1 micron size). This will direct you to choose the correct basket when ordering.

Operation

Unfiltered liquid enters the housing above the bag or basket and passes down through them. Solids are contained inside the bag or basket, where they're easily and completely removed when the unit is serviced.

Fluid bypass around the basket is prevented because the outside diameter of the filter bag seals radially against the housing inside diameter. A single cover gasket is used to seal the opening, and covers can be installed and removed without tools.

Model 6 Pressure Drop Data

Basket strainer and bag filters are usually selected so that the pressure drop does not exceed 2 psi, when they are clean. Higher pressure drops may be tolerated, when contaminant loading is low. Bag change out should occur at 15 psid.

The pressure drop data is accurate for all housings with strainer or bag filter baskets. When bag filters are added, total pressure drop becomes the sum of the pressure drop as determined by the steps below.

	Viscosity, cps								
	1 (H ₂ O)	50	100	200	400	600	800	1000	2000
All unlined baskets	.65	.85	1.00	1.10	1.20	1.40	1.50	1.60	1.80
40-mesh lined	.73	.95	1.20	1.40	1.50	1.80	1.90	2.00	2.30
60-mesh lined	.77	1.00	1.30	1.60	1.70	2.10	2.20	2.30	2.80
80-mesh lined	.93	1.20	1.50	1.90	2.10	2.40	2.60	2.80	3.50
100-mesh lined	1.00	1.30	1.60	2.20	2.40	2.70	3.00	3.30	4.40
200-mesh lined	1.30	1.70	2.10	3.00	3.40	3.80	4.40	5.00	6.80

Follow these easy steps:

- 1) Using the desired pipe size and approximate flow rate, determine the basic pressure drop from the appropriate graph.
- 2) Multiply the pressure drop obtained in step 1 by the viscosity correction factor found in the accompanying table. This is the adjusted (clean) pressure drop for all baskets, without filter bags.
- 3) Add the pressure drop for the bag filter.

Basket Data

Depth Nominal (inches)	Diameter (inches)	Surface Area (sq. ft.)	Volume (cu. in.)	Bag Size No.
12	5	1.3	235	7
18	5	2.0	350	8
30	5	3.4	630	9

Model 6 — For flow rates to 100 gpm*

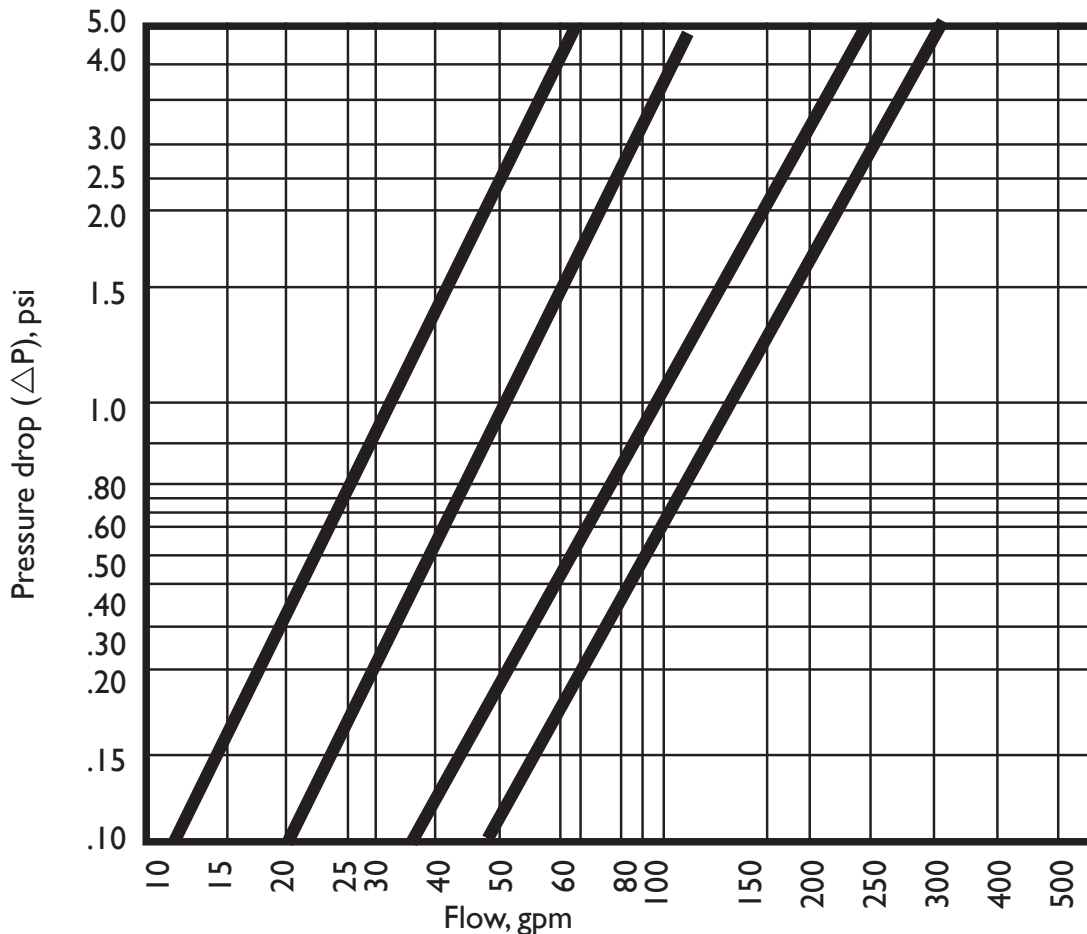

* Based on housing only. Fluid viscosity, bag filter used, and expected dirt loading should be considered when sizing a filter.

Model 6: Sizes #7, #8, & #9 — Available in three styles and four materials

Carbon Steel

304-316 Stainless Steel

Aluminum

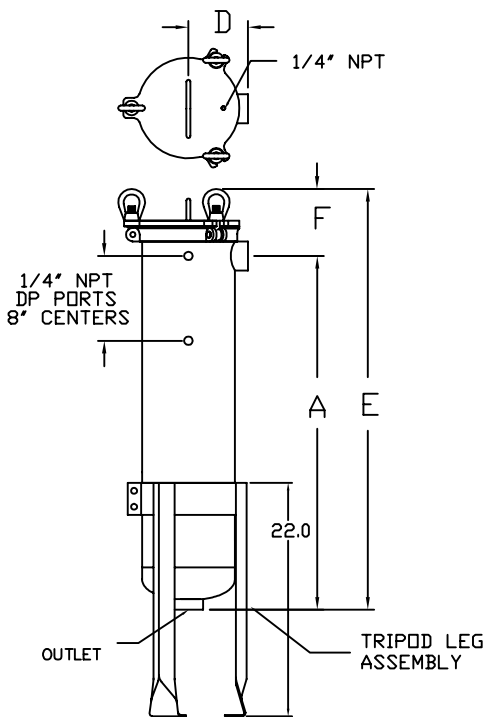

Style 1
Bottom Outlet

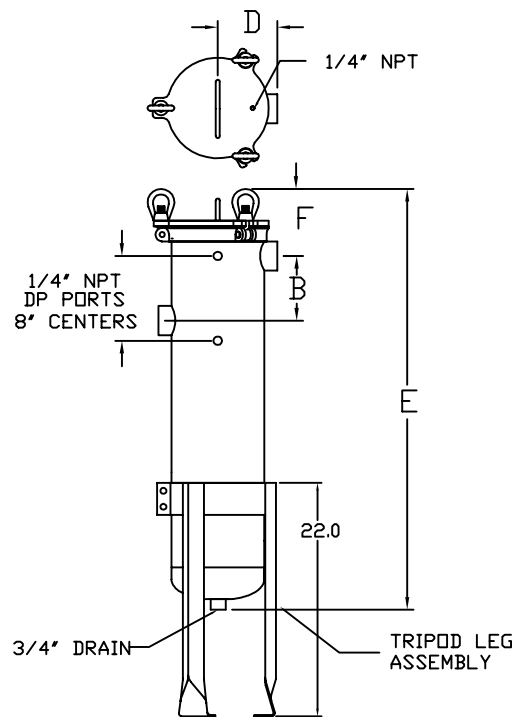

Style 2
Side Outlet Top

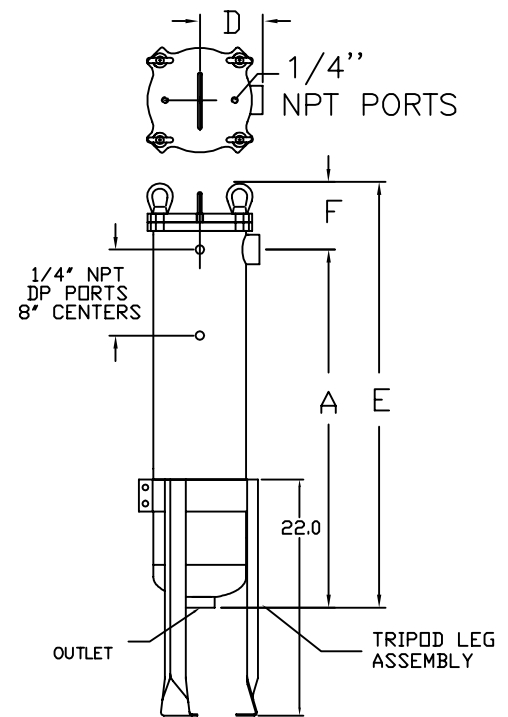

Style 2B
Side Outlet
Bottom

#7	Pipe Size	A	B	C	D	E	F
	In NPT						
SIZE 6-12	0.75	18.0	4.5	13	4.30	24.3	5.6
	1.00	18.1	4.5	13	4.30	24.5	5.7
	1.25	18.3	4.5	13	4.30	24.9	5.9
	1.50	19.3	4.5	13	4.30	25.6	6.1
	2.00	19.6	4.8	13	4.30	25.7	6.3
	3.00	20.1	6.3	13	4.30	26.8	6.9

#8	Pipe Size	A	B	C	D	E	F
	In NPT						
SIZE 6-18	0.75	22.5	4.5	27	4.30	28.7	5.6
	1.00	22.6	4.5	27	4.30	29.1	5.7
	1.25	22.8	4.5	27	4.30	29.3	5.9
	1.50	23.8	4.5	27	4.30	29.5	6.1
	2.00	24.0	4.8	27	4.30	29.7	6.3
	3.00	24.6	6.3	27	4.30	30.5	6.9

#9	Pipe Size	A	B	C	D	E	F
	In NPT						
SIZE 6-30	0.75	32.0	4.5	27.5	4.30	38.3	5.6
	1.00	32.1	4.5	27.5	4.30	38.5	5.7
	1.25	32.3	4.5	27.5	4.30	38.9	5.9
	1.50	33.3	4.5	27.5	4.30	39.6	6.1
	2.00	33.6	4.8	27.5	4.30	39.7	6.3
	3.00	34.1	6.3	27.5	4.30	40.8	6.9

Carbon Steel 304-316 Stainless Steel Aluminum

Standard Features

- Hinged Eye Bolt Cover (CS & SS)
- Eye Bolt Cover (Aluminum)
- 304 Stainless Basket
- Buna Seal
- 1/4" NPT Gauge Port
- Adjustable C.S. Legs

Options

- 316 Stainless Basket
- DP Ports
- O-Ring Seal Materials
- 304, 316 Adjustable Legs
- Flange Connections
- Sanitary Connections

How To Order Model 6: Size #7, #8 & #9 Filter Bag Housings

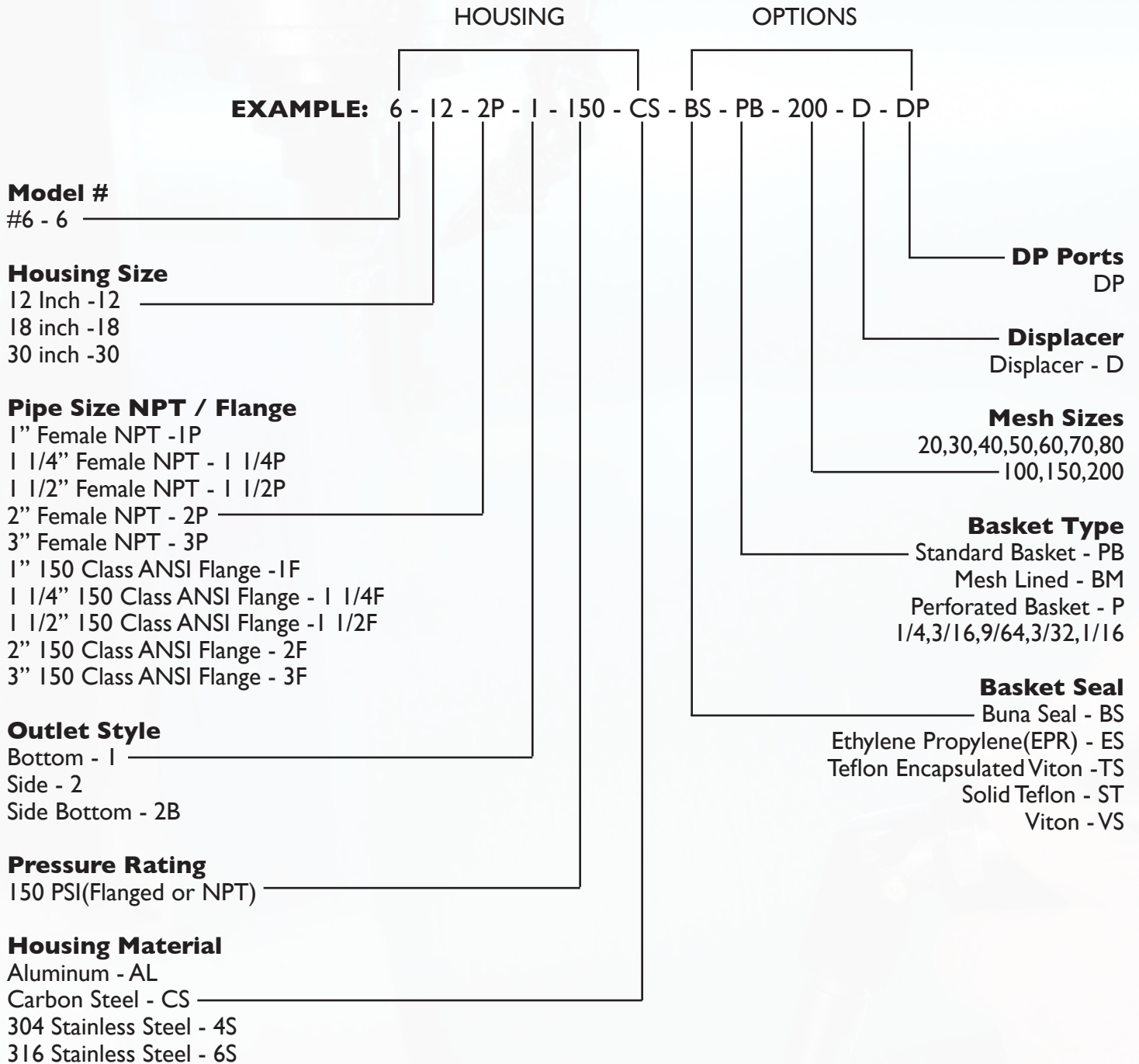

- * Aluminum Housings only available with Eye Bolt Covers
- * Carbon Steel & Stainless Housing only available with Hinged Eye Bolt Covers
- * All Filter Bag Housings come with Carbon Steel Legs & Standard 304 SS Basket
- * 304 Stainless & 316 Stainless Legs are available & 316 SS Baskets are available

Model 8 Bag Filter Housings Sizes #1 & #2 Strainers or Bag Filters: Your Choice!

Model 8 strainer/filter housings are made in 2 sizes and can serve as basket strainers (for particle retention down to 74 micron size) or as bag filters (for particle retention down to 1 micron size). In all cases, covers are easily removed without special tools.

Features

- Low pressure drops
- Permanently-piped housings
- Covers are O-ring sealed
- Carbon steel or stainless steel (304 or 316) and aluminum construction for housings
- Easy to clean!
- Adjustable-height legs, standard
- O-Ring seals: Buna N, EPR, Viton®, teflon®
- Duplex unites are available
- Pipe sizes 3/4 thru 4-inch, NPT or flanged
- Two basket depths: 15 or 30 inches (nominal)

Options

- Sanitary connections
- Different outlet connections
- Extra-length legs
- Liquid displacers for easier servicing



Model shown in Stainless Steel



Model shown in Carbon Steel

Choosing A Basket Strainer or Bag Filter

Choose between straining (removing particles down to 74 micron size) or filtering a fluid (removing particles down to 1 micron size). This will direct you to choose the correct basket when ordering.

Operation

Unfiltered liquid enters the housing above the bag or basket and passes down through them. Solids are contained inside the bag or basket, where they're easily and completely removed when the unit is serviced.

Fluid bypass around the basket is prevented because the outside diameter of the filter bag seals radially against the housing inside diameter. A single cover gasket is used to seal the opening, and covers can be installed and removed without tools.

Model 8 Pressure Drop Data

Basket strainer and bag filters are usually selected so that the pressure drop does not exceed 2 psi, when they are clean. Higher pressure drops may be tolerated, when contaminant loading is low. Bag change out should occur at 15 psid.

The pressure drop data is accurate for all housings with strainer or bag filter baskets. When bag filters are added, total pressure drop becomes the sum of the pressure drop as determined by the steps below.

	l (H ₂ O)	Viscosity, cps							
		50	100	200	400	600	800	1000	2000
All unlined baskets	.65	.85	1.00	1.10	1.20	1.40	1.50	1.60	1.80
40-mesh lined	.73	.95	1.20	1.40	1.50	1.80	1.90	2.00	2.30
60-mesh lined	.77	1.00	1.30	1.60	1.70	2.10	2.20	2.30	2.80
80-mesh lined	.93	1.20	1.50	1.90	2.10	2.40	2.60	2.80	3.50
100-mesh lined	1.00	1.30	1.60	2.20	2.40	2.70	3.00	3.30	4.40
200-mesh lined	1.30	1.70	2.10	3.00	3.40	3.80	4.40	5.00	6.80

Follow these easy steps:

- 1) Using the desired pipe size and approximate flow rate, determine the basic pressure drop from the appropriate graph.
- 2) Multiply the pressure drop obtained in step 1 by the viscosity correction factor found in the accompanying table. This is the adjusted (clean) pressure drop for all baskets, without filter bags.
- 3) Add the pressure drop for the bag filter.

Basket Data

Depth Nominal (inches)	Diameter (inches)	Surface Area (sq. ft.)	Volume (cu. in.)	Bag Size No.
15	6.7	2.3	500	1
30	6.7	4.4	1000	2

Model 8 — For flow rates to 220 gpm*

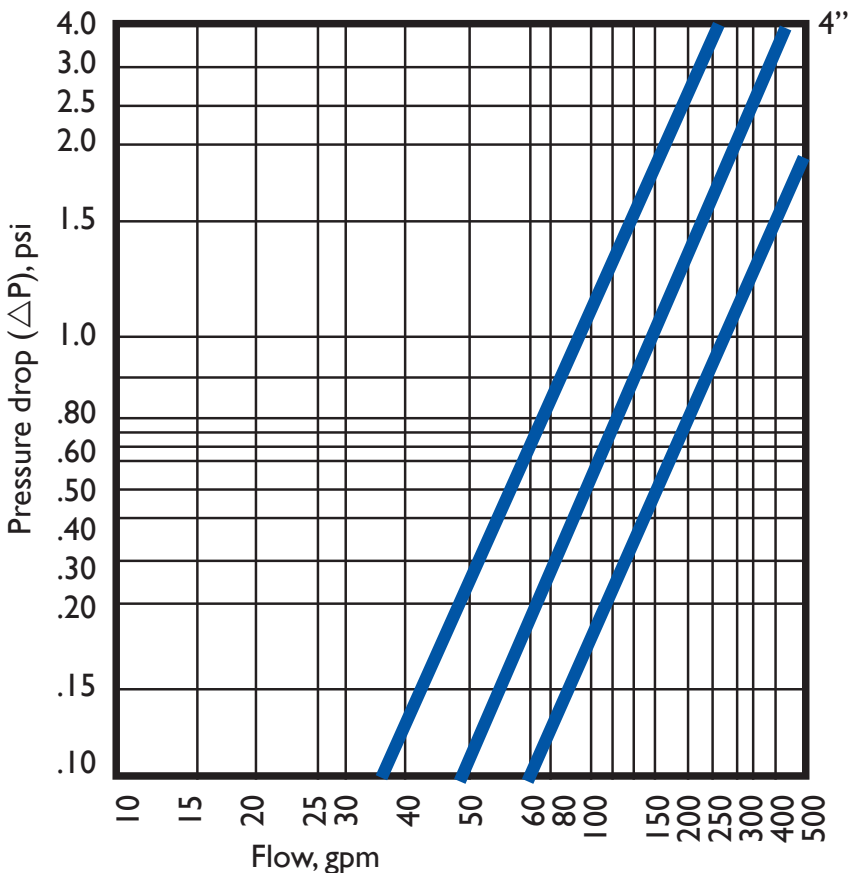

* Based on housing only. Fluid viscosity, bag filter used, and expected dirt loading should be considered when sizing a filter.

Model 8: Sizes #1 & #2 — Available in four styles and four materials

Carbon Steel

304-316 Stainless Steel

Aluminum

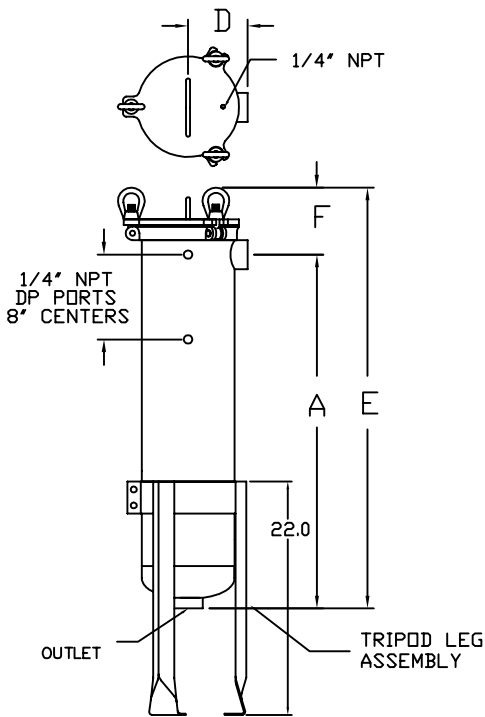

Style 1
Bottom Outlet

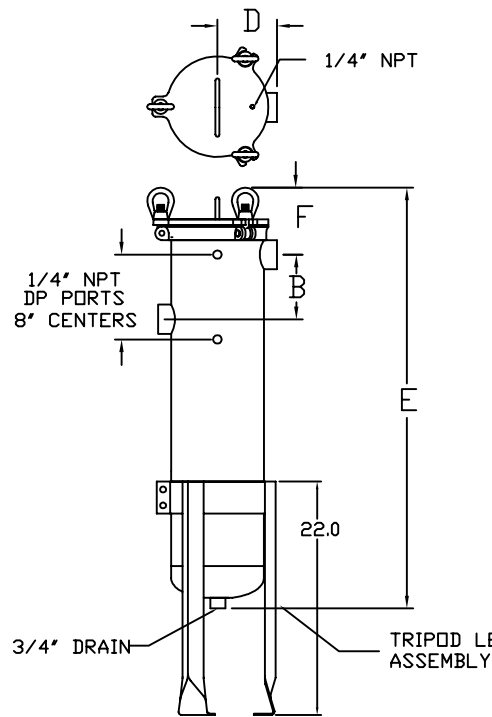

Style 2
Side Outlet Top

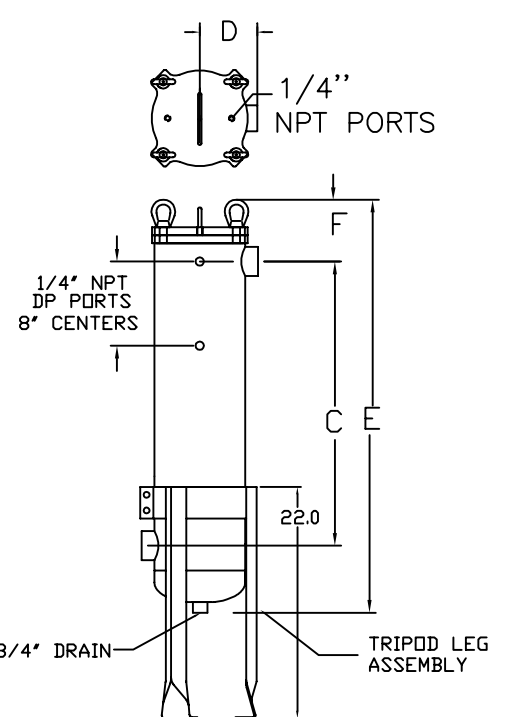

Style 2B
Side Outlet Bottom

Carbon Steel 304-316 Stainless Steel Aluminum

Standard Features

- Hinged Eye Bolt Cover (CS & SS)
- Eye Bolt Cover (Aluminum)
- 304 Stainless Basket
- Buna Seal
- 1/4" NPT Gauge Port
- Adjustable C.S. Legs

Options

- 316 Stainless Basket
- DP Ports
- O-Ring Seal Materials
- 304, 316 Adjustable Legs
- Style 3 90 Elbow
- Flange Connections
- Sanitary Connections

#1	Pipe Size	A	B	C	D	E	F
	In NPT						
SIZE 8-15	0.75	30.5	5.6	13	5.3	24.3	5.6
	1.00	30.5	5.6	13	5.3	24.5	5.7
	1.25	30.5	5.6	13	5.3	24.9	5.9
	1.50	30.5	5.6	13	5.3	25.6	6.1
	2.00	30.5	6.1	13	5.3	25.7	6.3
	3.00	30.5	7.3	13	5.3	26.8	6.9
	4.00	30.5	8.3	13	5.3	27.9	7.4

#2	Pipe Size	A	B	C	D	E	F
	In NPT						
SIZE 8-30	0.75	34.5	5.6	27	5.3	38.3	5.6
	1.00	34.5	5.6	27	5.3	38.5	5.7
	1.25	34.5	5.6	27	5.3	38.9	5.9
	1.50	34.5	5.6	27	5.3	39.6	6.1
	2.00	34.5	6.1	27	5.3	39.7	6.3
	3.00	34.5	7.3	27	5.3	40.8	6.9
	4.00	34.5	8.3	27	5.3	41.9	7.4

How To Order Model 8: Size #1 & #2 Filter Bag Housings

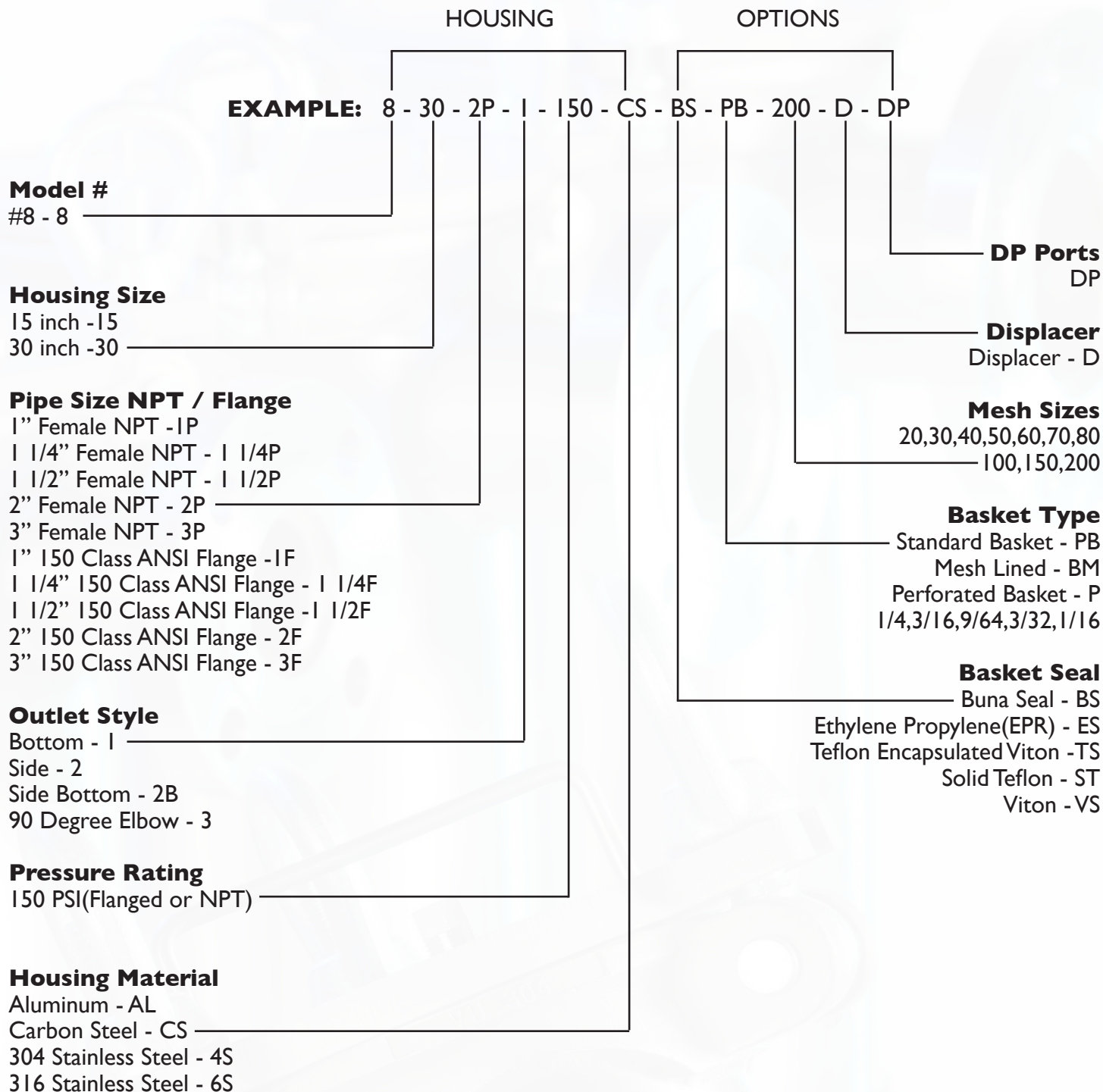

* Aluminum Housings only available with Eye Bolt Covers

* Carbon Steel & Stainless Housing only available with Hinged Eye Bolt Covers

* All Filter Bag Housings come with Carbon Steel Legs & Standard 304 SS Basket

* 304 Stainless & 316 Stainless Legs are available & 316 SS Baskets are available

Model D8 Duplex Bag Filter Housings Trouble-free, continuous operation

Duplex filters permit continuous operation, reducing overall operating costs. Flow can be switched back and forth between two filter vessels, allowing one side to be serviced while the other is in use.

A duplex housing, using a single multi-port valve operating system, is a better solution, and offers many benefits:

- Four separate valves are used all operated simultaneously by a single lever.
- Valves use the standard butterfly design, known for their effective seal, low pressure drop, and low cost.
- Any of the valves can be serviced individually, without need to disturb the other valves or piping. Replacements are readily available.
- Valves are soft-seated to provide bubble-tight closure.
- A variety of valve seal materials are available for use with a number of hard-to-handle fluids.
- Pressure drop is minimized because the flow path has the equivalent of only four elbows instead of the usual six.
- Mechanical stops assure that the valves are completely open or closed.
- A single-valve pressure balancing vent system is furnished to ease movement of the lever and to fill the just serviced vessel before use.
- Vents in filter covers and drain ports in filter housing speed evacuation and filling.

Basket Data *(each basket, two baskets total)*

Depth Nominal (inches)	Diameter (inches)	Surface Area (sq. ft.)	Volume (cu. in.)	Bag Size No.
15	6.7	2.3	500	1
30	6.7	4.4	1000	2

Features

- Low pressure drops
- Permanently-piped housings
- Covers are O-ring sealed
- Carbon steel or stainless steel (304 or 316)
- NPT or Flange styles
- Adjustable-height legs, standard
- Large-area, heavy-duty baskets

Options

- 316 stainless steel basket perforation
- Extra-length legs
- Liquid displacers for easier servicing
- DP ports

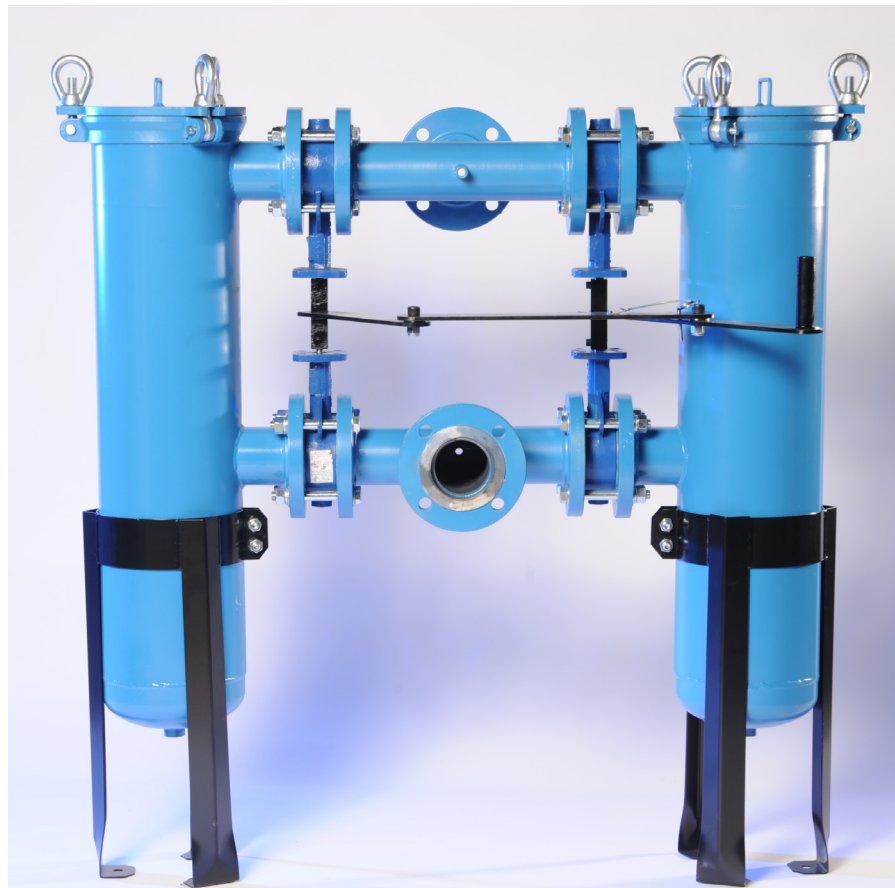

Duplex Housing Model shown in Carbon Steel

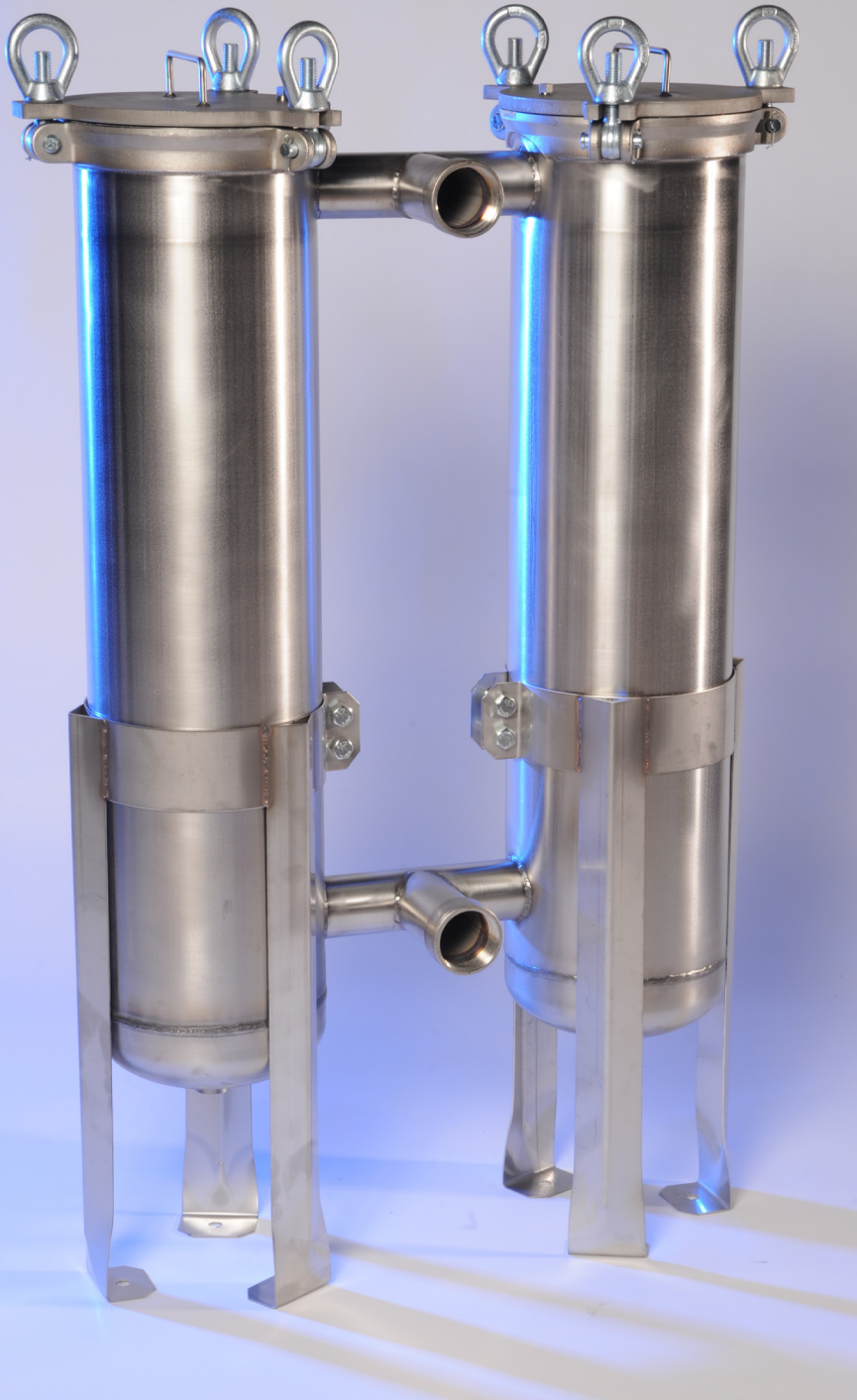

Dual Housing Model shown in Stainless Steel

Model 88 Dual Bag Filter Housings Extra capacity at higher flow rates!

Dual capacity housings can serve as either basket strainers or bag filters. Covers are easily removed without tools, and the basket or bag is quickly and easily replaced.

Low price, greater dirt holding capacity, and higher flow rates make the 88 housing a very cost-efficient choice.

Features

- Low pressure drops
- Permanently-piped housings
- Covers are O-ring sealed
- Carbon steel or stainless steel (304 or 316)
- NPT or Flange styles
- Adjustable-height legs, standard
- For flow rates to 440 gpm*
- Large-area, heavy-duty baskets

Options

- 316 stainless steel basket perforation
- Extra-length legs
- Liquid displacers for easier servicing
- Mesh sizes
- DP ports
- Sanitary connections

* Based on housing only. Fluid viscosity, bag filter used, and expected dirt loading should be considered when sizing a filter.

Basket Data *(each basket, two baskets total)*

Depth Nominal (inches)	Diameter (inches)	Surface Area (sq. ft.)	Volume (cu. in.)	Bag Size No.
15	6.7	2.3	500	1
30	6.7	4.4	1000	2

ASME Code and Non-Code
Bag Filter Housings
Cartridge Filter Housings
Strainer Housings
Simplex-Duplex-Multiplex



RAY CAMP COMPANY

P.O. Box 7
Palmetto, GA 30268
Tel 404-766-4940
Fax 404-766-0008
sales@raycamp.com
www.raycamp.com

